



The Village of
PORT CLEMENTS
"Gateway to the Wilderness"

36 Cedar Avenue West
PO Box 198
Port Clements, BC
V0T1R0
OFFICE: 250-557-4295
Public Works: 250-557-4295
FAX: 250-557-4568
Email: office@portclements.ca
Web: www.portclements.ca

7:00 p.m. Regular Meeting of Council Tuesday September 6, 2016

AGENDA

1. **ADOPT AGENDA**
2. **PETITIONS, DELEGATIONS & OPENING OF SEALED TENDERS**
D-1 – Weight Room Ideas – Presented by Ruth Bellamy
3. **MINUTES**
M-1 – August 15, 2016 Regular Council meeting minutes
4. **BUSINESS ARISING FROM THE MINUTES & UNFINISHED BUSINESS**
5. **ORIGINAL CORRESPONDENCE**
C-1 – Eagle Transit – Proposed Rate Change
C-2 – SQCRD Board Meeting Highlights
C-3 – Jennifer Rice, MLA – Acknowledgement Letter for Canada Days
C-4 – Statistics Canada – Acknowledgement email for 2016 Census
6. **GOVERNMENT**
G-1 – Bylaw #434, 2016 – Amendment to Dangerous Dog Bylaw – Reconsider & Adopt
G-2 – Bylaw #435, 2016 – Ticket Information Bylaw – Reconsider & Adopt
7. **FINANCE**
F-1 Cheque Listing to August 31, 2016
8. **NEW BUSINESS**
NB-1 – Trail Extension - Project Options
NB-2 – Zoning, Building and Sub-Division Bylaw Review
9. **REPORTS & DISCUSSIONS**
10. **ACTION ITEMS**
11. **QUESTIONS FROM THE PUBLIC & PRESS**
12. **ADJOURNMENT**

Proposal for Weight Room Equipment

Weight bench with rack:

1. Treadmillfactory.ca – Best Fitness Olympic Bench
329.00
2. Costco - Marcy Deluxe Mid Size Olympic weight bench
359.99
3. Fitness Depot - Northern Lights Decline Olympic Workout Centre Bench
348.00 (regular price 529.00)

Olympic bar collars

1. Treadmillfactory.ca – spring collars
9.99 per pair
2. Fitness Depot - spring or alternative collar
3.00 each

Shipping

1. Treadmillfactory.ca – 62.51
2. Fitness Depot - 195.00
3. Costco - shipping included in price.



Warehouse Savings

Find a Warehouse

Get Email Offers

Customer Service

Canada

AB

EN

Search Costco

Sign In / Register

Cart

All Departments Pharmacy Services Photo Travel Optical Membership Locations

Home Sports & Fitness Exercise & Fitness Strength & Core Training



Marcy Deluxe Mid Size Olympic Weight Bench with Arm Curl Pad

Features: Large Bicep Curl Pad, Dual Function Leg Developer, Four Position Back Pad

Compare product

★★★★★ Write a review

Share This Product:

Print this Page

Item #1002249

Your Price **\$359.99**

Shipping & Handling Included

QUANTITY 1

Add to Cart

Add to Wish List

The estimated delivery time will be approximately 7 - 10 business days from the time of order.

Product Details Specifications Shipping & Terms Returns/Warranty Reviews

This 2-piece designed mid-size Olympic bench allows for a more versatile workout, including walk-in squat and lunge exercises. This bench features a 6-position back pad. The dual function leg developer has pivot points that align with the knee joints. It also features an adjustable preacher curl pad and contoured comfortable foam roller pads.

Features:

- 5.1 cm x 5.1 cm (2 in. x 2 in.) 14 gauge square steel tubing
- Boxed side construction upholstery with high density foam and accentuated vinyl
- Durable powder coat finish
- Compact frame design
- Accepts Standard and Olympic size barbell and weight plates
- Easy to assemble
- Arm curl pad included

Specifications:

- Dimensions (L x W x H): 178 cm x 109 cm x 165 cm (70 in. x 43 in. x 65 in.);
- Weight: 38.5 kg (85 lb.)

Warranty:

- 2 years limited

Model: MKB 869

Standard shipping via UPS is included in the quoted price. The estimated delivery time will be approximately 7 - 10 business days from the time of order. For more information regarding UPS delivery, click here.

This item is subject to some delivery restrictions. Please proceed to checkout to verify if delivery is available to your postal code.

Costco.ca products can be returned to any of our more than 600 Costco warehouses worldwide.

TDI



Search entire store here...

[Home](#) / [Strength](#) / [Strength Equipment](#) / **Northern Lights Decline Olympic Workout Center Bench**

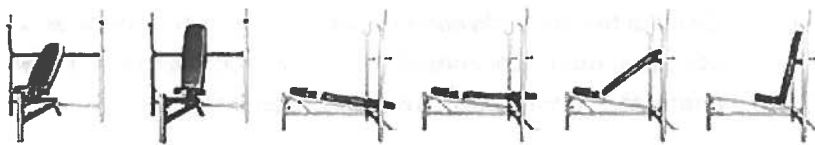
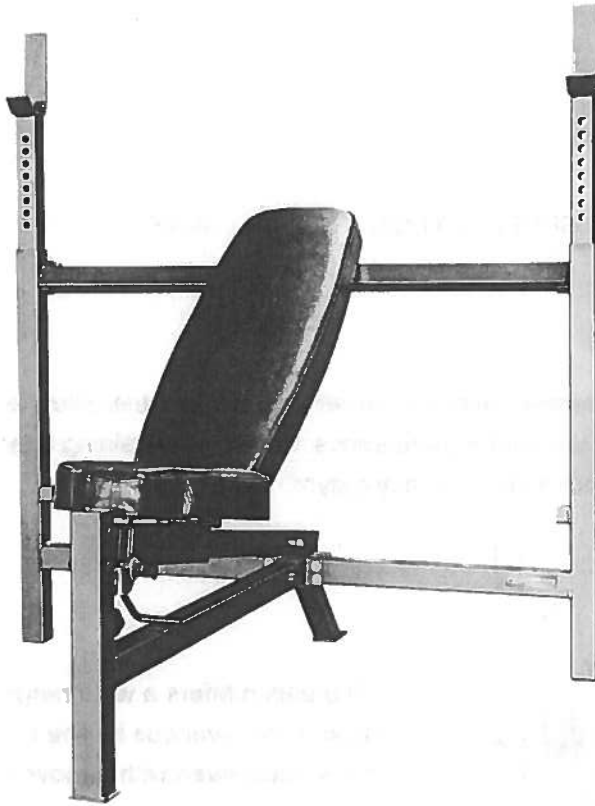

Northern Lights Decline Olympic Workout Center Bench

[Read](#) | [Write a review](#)



[Questions? We're here to help!](#)

MSRP: \$529.00

SAVE: \$181.00

OUR PRICE \$348.00

To buy this item online

[CLICK HERE](#)

Like

0

Tweet

G+1

0

DESCRIPTION

SPECIFICATIONS

WARRANTY

MANUAL

DESCRIPTION

The Northern Lights Decline Olympic Workout Center Bench offers the ultimate in adjustments and quality for any athlete. No matter your size, workout preferences, or available training space, this heavy-gauge steel workout center bench is the perfect addition to any gym.

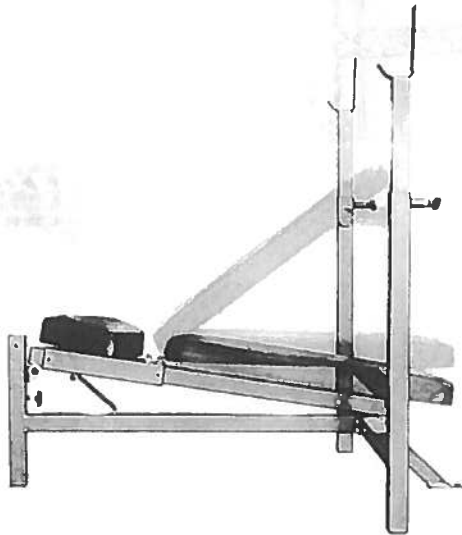

The bench offers a wide range of features for users to adjust. With various incline levels ranging from flat to 90°. This is achieved with a moveable stopping bar. The workout center bench can also be combined with a variety of optional attachments, which allows you to save space and add even more functionality to your bench, making it a great alternative to traditional workout center benches.

The sliding base of the bench can extend the bench from the 60° incline to its full 90° incline. This is done with a pull pin lock system. The bar hooks are also adjustable with a pull pin system. The adjustable height extends from 34" to 59" from the floor.

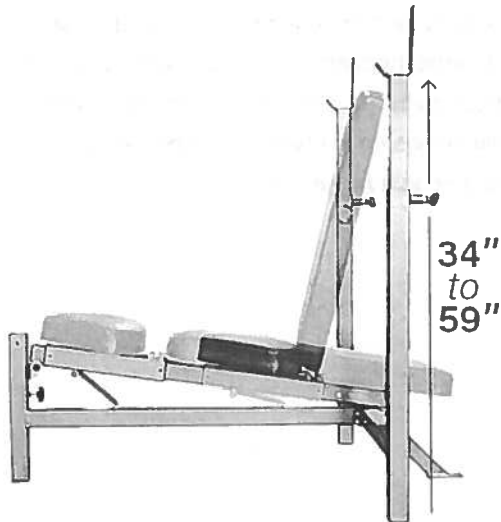

Features

- Adjusts from a 15° decline to 90° upright
- Heavy Gauge Steel Construction
- Ergo-Tech Padding
- Charcoal Powder Coated Finish

WARRANTY

Manufacturer's limited lifetime warranty against broken welds and manufacturing defects.

CUSTOMER REVIEWS

1 Review(s) | [Write a review](#)

Quality

Price

Value

RANDOMREVIEWER2015

(Posted on 2016-02-01)

a reliable utilitarian set

i've had one of these since late 2010 and have used it plenty and never had any problem with it. i've taken it apart and put it back together a few times too and still it holds together and it's reliability is very good. don't make the mistake i made though of tightening the nuts and bolts too tight as i created a circular depression into the bottom horizontal bar where the bolts are inserted and also warped the washers too so much that they are pretty dome shaped now.

like i said reliability is awesome but this is definitely a utility set built with only function in mind there is hardly anything comfortable, pleasant and eye pleasing about the set but it definitely gets the job done. also has room for attachments that insert in the vertical post directly forward of the butt pad.

it's fun to use on a decline setting for a bench press and can also be used as a incline setting but the the maximum height at which you can set the side posts to rest the barbell is a little lacking to me and make it effectively difficult and slightly unsafe in my opinion when picking up and setting the barbell while sitting on a higher incline.

PRODUCT HIGHLIGHTS

SKU	NLDOWB
Availability	IN STOCK
Manufacturer	Northern Lights
Country of Origin	Canada
Free Shipping	No



CUSTOMER SERVICE +

CORPORATE +

SERVICES +

FIND A STORE

[PRIVACY & SECURITY](#) | [CONTACT US](#) | [TERMS OF USE](#)

© 2016 Fitness Depot. All Rights Reserved.



Home Strength Equipment Benches Olympic Benches Best Fitness Olympic Bench - BFOB10

Best Fitness Olympic Bench - BFOB10



item# 1087

Market Price: \$349.00 **SAVE**
\$20.00

\$329.00

Qty:

+

**ADD TO
CART**

COMPARE WISHLIST FIND A
STORE

FLAGSHIP STORE	MARKHAM, ON	(905) 944-0090
	TORONTO, ON	(416) 646-0300
	MISSISSAUGA, ON	(905) 828-9033
	BARRIE, ON	(705) 719-0160
	LONDON, ON	(519) 681-6633
	COMMERCIAL SALES	(905) 205-0424



Be the first to review this product

[Overview](#) [Details and Specs](#) [Product Questions](#) [Reviews](#)

Features

The Best Fitness Olympic Folding Bench is ideal for a variety of barbell and dumbbell exercises. The quick-change safety pull pin allows multiple back pad adjustments, allowing you to move smoothly and safely through your routines. It accommodates users of any size with varying height adjustments and is designed to fit both 6-foot and 7-foot bars and also comes with leg curl/leg developer extension. Best of all, when you're done for the day, the Best Fitness Olympic Folding Bench collapses to a manageable, storable size.

You can build a full, strong chest with flat bench press exercises alone. Adding incline routines will complement your chest development while you work to build your upper pectoral muscle areas. Changing the angle of incline puts extra stress on the upper chest muscles and your front deltoids.

Cover all the angles with the Best Fitness Olympic Folding Bench, and take advantage of its many features and benefits:

- Fold-Up storage design for space-saving convenience.
- Multiple flat, incline adjustments for a well-rounded chest workout.
- Durable powder coated finish.
- An ideal companion to the Best Fitness Olympic Multi-Press Rack.

Specs

- Adjustable flat to incline
- Adjustable uprights
- Folding space saving design
- 58" High x 68" Long x 41" Wide
- Includes leg developer



olympic collars

Home / Search results for: 'olympic collars'

SEARCH RESULTS FOR 'OLYMPIC COLLARS'

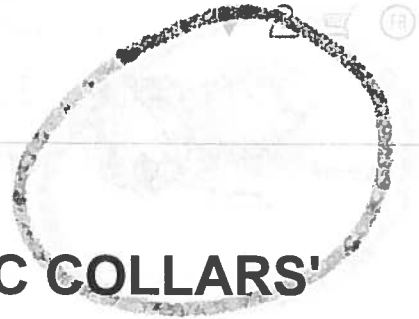

Price (low - high) ▾

Show 24 ▾

Page: 1 2 3 »
(1-24 of 51)



Northern Lights

Regular Spring Collar (Priced per collar)

\$1.88 MSRP: \$2.99
SAVE: \$1.11

[Add to cart](#)



Northern Lights

Regular Chrome Threaded Collar

\$1.98 MSRP: \$4.99
SAVE: \$3.01

[Add to cart](#)

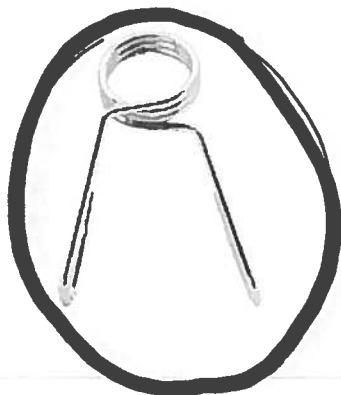

Northern Lights

Olympic Spring Collar (Priced per Collar)

\$3.00 MSRP: \$4.99
SAVE: \$1.99

[Add to cart](#)

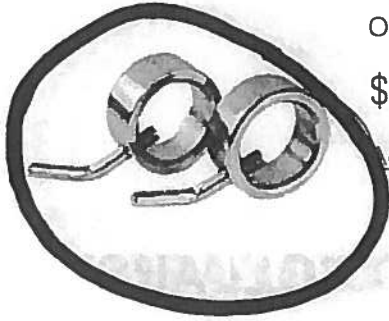

Northern Lights

Olympic Collar (Priced per collar)

\$3.00 MSRP: \$4.99
SAVE: \$1.99

[Add to cart](#)

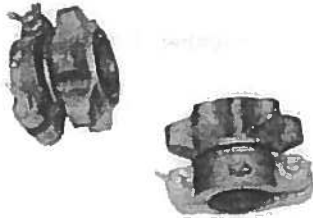

Northern Lights

Olympic Spinlock Collar

\$8.88 MSRP: \$14.99
SAVE: \$6.11

[Add to cart](#)



Northern Lights

Olympic Collars with Leverage Arm - Pair

\$14.88 MSRP: \$18.88
SAVE: \$4.00

[Add to cart](#)

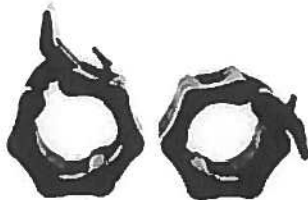

Northern Lights

Hex Lock Olympic Collars - Pair

\$14.88 MSRP: \$39.99
SAVE: \$25.11

[Add to cart](#)

Northern Lights

Star Lock Olympic Collar, Red

\$14.88 MSRP: \$22.99
SAVE: \$8.11

[Add to cart](#)



Handwritten mark

Home Strength & Conditioning Lifting Bars Collars & Accessories **Element Fitness 2" Olympic Spring Collars - Pair**

Element Fitness 2" Olympic Spring Collars - Pair



item# 1469

Market Price: \$14.99 **SAVE \$5.00**

\$9.99

Qty:

- +

**ADD TO
CART**



COMPARE WISHLIST **FIND A STORE**

FLAGSHIP STORE	MARKHAM, ON	(905) 944-0090
	TORONTO, ON	(416) 646-0300
	MISSISSAUGA, ON	(905) 828-9033
	BARRIE, ON	(705) 719-0160
	LONDON, ON	(519) 681-6633
	COMMERCIAL SALES	(905) 205-0424

Be the first to review this product

Overview Details and Specs

Product Questions Reviews

Olympic Spring Collar (Pair)

Color: Chromed Finish

Hole Diameter: 2 inches

Rubber hand grips

Quantity Sold w Each Purchase: Sold in Pairs

You may also be interested in the following product(s)



Lock-Jaw HEX - 2" Olympic Barbell Collars - Black

\$29.99



Lock-Jaw Pro - 2" Olympic Barbell Collars - Black

\$39.99



Lock-Jaw Barbell C

\$54.9



The Village of
PORT CLEMENTS
"Gateway to the Wilderness"

36 Cedar Avenue West
PO Box 198
Port Clements, BC
V0T1R0
OFFICE: 250-557-4295
Public Works: 250-557-4295
FAX: 250-557-4568
Email: office@portclements.ca
Web: www.portclements.ca

Minutes of the regular meeting of the Port Clements Council held August 15, 2016 in Council Chambers.

Present:

Mayor Gould
Councilor Daugert
Councilor Cunningham
Councilor O'Brien Anderson
Councilor Gaspar

CAO Kim Mushynsky
Deputy Clerk Ruby Saunders/Decock
Public Works Superintendent Sean O'Donoghue

Mayor Gould called the meeting to order at 7:02 p.m.

1. ADOPT AGENDA.

2016-203 – Moved by Councilor Cunningham, seconded by Councilor Daugert
THAT Council adopts the agenda as presented.

CARRIED

2. PETITIONS, DELEGATIONS & OPENING OF SEALED TENDERS.

3. MINUTES.

M-1– August 2, 2016 Regular Council Meeting

2016-204 – Moved by Councilor Daugert, seconded by Councilor Cunningham

THAT Council adopts the August 2, 2016 Regular Council meeting minutes correcting T-1 to say Janitorial Contract and not Trail Project.

CARRIED

M-2 – June 9, 2016 Tourism Committee minutes

2016-205 – Moved by Councilor Cunningham, seconded by Councilor O'Brien Anderson

THAT Council receives the June 9, 2016 Tourism Committee minutes as presented.

CARRIED

4. BUSINESS ARISING FROM THE MINUTES & UNFINISHED BUSINESS.

5. ORIGINAL CORRESPONDENCE

C-1 – MIEDS July 2016 Grant Writer Report

2016-206 – Moved by Councilor O'Brien Anderson, seconded by Councilor Gaspar

THAT Council receives the July 2016 Grant Writer Report.

CARRIED

C-2 – Museum – 20 years of attendance data

M-1

2016-207 – Moved by Councilor Gaspar, seconded by Councilor Daugert
THAT Council receives the Museum statistical report.

CARRIED

6. GOVERNMENT

G-1 – Bylaw #434, 2016 Amendment to the Dangerous Dog Bylaw

2016-208 – Moved by Councilor O'Brien Anderson, seconded by Councilor Cunningham

THAT Council does 3rd reading for Bylaw #434, 2016 – Amendment to the Dangerous Dog Bylaw

CARRIED

2016-209 – Moved by Councilor Gaspar, seconded by Councilor Cunningham

THAT the Village of Port Clements test pilot using the ball diamond as an off-leash area under specific situations and that we add dog litter bags and signage to explain the expectations of users. In April 2017 Council will re-evaluate the off-leash concept to determine if it will continue.

CARRIED

G-2 – Bylaw #435, 2016 Ticket Information Bylaw

2016-210 – Moved by Councilor Gaspar, seconded by Councilor Daugert

THAT Council does 3rd reading for Bylaw #435, 2016 – Ticket Information Bylaw

CARRIED

7. FINANCE

F-1 – Cheque Listing to August 5, 2016

2016 – 211 - Moved by Councilor Cunningham, seconded by Councilor Gaspar

THAT Council receives this Report.

CARRIED

8. NEW BUSINESS

NB-1 – Rainbow Wharf repairs discussion

2016-212 – Moved by Councilor Daugert, seconded by Councilor Gaspar

THAT Council receives this report

CARRIED

NB-2 – Derelict property discussion

2016-213 – Moved by Councilor Daugert, seconded by Councilor O'Brien Anderson

THAT Council sends a letter acknowledging the efforts so far to clean up the property and request that he continue to move in that direction.

CARRIED

9. REPORTS & DISCUSSIONS

Mayor Gould – SQCRD Mtg, NW Reg Hospital Mtg, Forestry mtg

Councilor Daugert – Community Hall repairs update

Councilor Cunningham – Agate Triathlon

Councilor O'Brien Anderson – no report

Councilor Gaspar – no report

CAO Mushynsky – request for motion regarding change of signers

2016-214 – Moved by Councilor Cunningham, seconded by Councilor Daugert

THAT Council authorizes the Administrator to remove Glenda Saruga from the signing authority list and add Ruby Saunders/Decock.

CARRIED

10. ACTION ITEMS

11. QUESTIONS FROM THE PUBLIC & PRESS

2016-215 – Moved by Councilor Cunningham, seconded by Councilor Gaspar
THAT Council moves to an in-camera meeting per Community Charter Section 90(1)(c) at 8:15pm.
CARRIED

ADJOURNMENT

2016-216 – Moved by Councilor Gaspar, seconded by Councilor Cunningham
THAT the meeting be adjourned at 8:25pm.
CARRIED

Ian Gould
Mayor

Kim Mushynsky
CAO



EAGLE TRANSIT LTD.
 Transit / Charter Bus / Taxi / Deliveries

August 8, 2016

Village of Port Clements
 Box 198
 Port Clements, BC V0T 1R0

Attention: Ian Gould, Mayor

Dear Mr. Gould,

RE: Proposed Rate Change

Eagle Transit has made an application to adjust the taxi rates currently charged to a customer.

As required by the Passenger Transportation Board, enclosed are schedules of the current rates and proposed rates for your review.

Please direct any comments regarding the proposed rate change to:

Passenger Transportation Board		
Phone: 250-953-3777	202 – 940 Blanshard Street	PO Box 9850 STN PROV GOVT
Fax: 250-953-3788	Victoria, British Columbia V8W 9T5	Victoria, British Columbia V8W 9T5
Email: ptboard@gov.bc.ca		
Web Site: www.ptboard.bc.ca		

Yours truly,

Marilyn Wilkins

Enclosures

c. Passenger Transportation Branch

250-559-4461
 250-559-2368 fax
eagle@haidagwaii.net

Box 476
 Queen Charlotte, BC
 V0T 1S0

POINT-TO-POINT RATES PT Board Form 12 (proposed)

OPERATOR LEGAL NAME: Eagle Transit Ltd.

TRANSPORTATION SERVICE: Taxi

POINT-TO-POINT			
Trip Description		Size of Vehicle (maximum capacity)	Rate \$
From	To		
Zone A Hayden Turner Campground to 3604 Oceanview Dr., Village of Queen Charlotte	Zone A Hayden Turner Campground to 3604 Oceanview Dr., Village of Queen Charlotte	4 passengers	9.52
		7 passengers	14.29
Zone A Hayden Turner Campground to 3604 Oceanview Dr., Village of Queen Charlotte	Zone B 3605 Oceanview Dr., Village of Queen Charlotte to Skidegate Landing including BC Ferries terminal; and Haida Heritage Center	4 passengers	14.29
		7 passengers	19.05
Zone A Hayden Turner Campground to 3604 Oceanview Dr., Village of Queen Charlotte	Zone C Skidegate	4 passengers	19.05
		7 passengers	23.81
Zone B 3605 Oceanview Dr., Village of Queen Charlotte to Skidegate Landing including BC Ferries terminal; and Haida Heritage Center	Zone A Hayden Turner Campground to 3604 Oceanview Dr., Village of Queen Charlotte	4 passengers	14.29
		7 passengers	19.05
Zone B 3605 Oceanview Dr., Village of Queen Charlotte to Skidegate Landing including BC Ferries terminal; and Haida Heritage Center	Zone B 3605 Oceanview Dr., Village of Queen Charlotte to Skidegate Landing including BC Ferries, Skidegate terminal; and Haida Heritage Center	4 passengers	14.29
		7 passengers	19.05
Zone B 3605 Oceanview Dr., Village of Queen Charlotte to Skidegate Landing including BC Ferries terminal; and Haida Heritage Center	Zone C Skidegate	4 passengers	14.29
		7 passengers	19.05

C-1

POINT-TO-POINT RATES PT Board Form 12 (proposed)

OPERATOR LEGAL NAME: Eagle Transit Ltd.

TRANSPORTATION SERVICE: Taxi

POINT-TO-POINT			
Trip Description		Size of Vehicle (maximum capacity)	Rate \$
From	To		
Zone C Skidegate	Zone A Hayden Turner Campground to 3604 Oceanview Dr., Village of Queen Charlotte	4 passengers	19.05
		7 passengers	23.81
Zone C Skidegate	Zone B 3605 Oceanview Dr., Village of Queen Charlotte to Skidegate Landing including BC Ferries terminal; and Haida Heritage Center	4 passengers	14.29
		7 passengers	19.05
Zone C Skidegate	Zone C Skidegate	4 passengers	9.52
		7 passengers	14.29
Minimum credit card transaction			14.29
Requested stop, no wait			1.91
Requested stop and wait; each 5 minutes or portion thereof			1.91

0-1

POINT-TO-POINT RATES PT Board Form 12 (proposed)

OPERATOR LEGAL NAME: Eagle Transit Ltd.

TRANSPORTATION SERVICE: Taxi

Point-to-Point			
Trip Description		Size of Vehicle (maximum capacity)	Rate \$
From	To		
Village of Queen Charlotte or Skidegate	Miller Creek	4 passengers	23.81
		7 passengers	28.57
Village of Queen Charlotte or Skidegate	Lawn Hill	4 passengers	33.33
		7 passengers	42.86
Village of Queen Charlotte or Skidegate	Tlell	4 passengers	71.43
		7 passengers	80.95
Village of Queen Charlotte or Skidegate	Port Clements	4 passengers	109.52
		7 passengers	119.05
Village of Queen Charlotte or Skidegate	Nadu Rd., Highway 16; New Town; Village of Masset; Old Massett; Masset Airport YMT	4 passengers	169.52
		7 passengers	190.48
Village of Queen Charlotte or Skidegate	Between Masset Airport YMT and bridge at Chown River	4 passengers	193.33
		7 passengers	214.29
Village of Queen Charlotte or Skidegate	Between bridge at Chown River and Hiellen River; Tow Hill parking lot, Naikoon Park	4 passengers	217.14
		7 passengers	238.10
Village of Queen Charlotte or Skidegate	Sandspit and Sandspit Airport	4 passengers	190.48
		7 passengers	238.10
Each requested stop, no wait			1.91
Each requested stop and wait; each 10 minutes or portion thereof			9.52
Wait time after initial 10 minutes of scheduled pick-up time; each 10 minutes or portion thereof			9.52
Cancellation on reserved day of travel			Full fare
Cancellation prior to reserved day of travel		47.62 or full fare, whichever is less	

C-1

EAGLE TRANSIT LTD.

TRANSPORTATION SERVICE: Taxi

Rates at August 8, 2016

	Zone A	Zone B	Zone C	Zone D	Zone E	Zone F
Zone A Queen Charlotte Crabapple Creek up to ½ Kilometer past paved portion of Honna Road including Wensch, Pineault and Bigelow residences	7.62	9.52	11.43	13.33	16.19	18.10
Zone B Queen Charlotte From Cascadia Causeway up to and including Moonglow B&B along 3 rd Avenue/Road 33 and all points north and south of 3 rd Avenue/Road 33	9.52	7.62	9.52	11.43	14.29	16.19
Zone C Queen Charlotte Funk Road up to an including bottom of Eagle Hill Road	11.43	9.52	7.62	9.52	12.38	14.29
Zone D Queen Charlotte/Skidegate Eagle Hill Road (top) to Second Beach, Skidegate including BC Ferries, Skidegate Landing, Haida Gwaii Museum and Haida Heritage Center	13.33	11.43	9.52	9.52	11.43	14.29
Zone E Skidegate Past 2 nd Beach to 100's, 200's, 300's, 400's, 500's, 600's, Skidegate Heights, Skidegate Properties, Mountain View and Skidegate Vista	16.19	14.29	12.38	11.43	11.43	14.29
Zone F Skidegate Those areas of Skidegate not in Zone D or Zone E including Skidegate Industrial Park, Balance Rock, Skidegate Treatment Plant	18.10	16.19	14.29	14.29	14.29	16.19

Rates reflect one-way travel with no requested stops or waiting; GST not included

EAGLE TRANSIT LTD.

TRANSPORTATION SERVICE: Taxi

Rates at August 8, 2016

To or From Queen Charlotte, Skidegate Landing, BC Ferries, Skidegate Terminal, or Skidegate	
Rennell Sound	\$190.48 plus off-road surcharge
Miller Creek and SQCRD Waste Management site	\$23.81
Lawn Hill	\$38.10
Dead Tree Point	\$47.62
Tlell	\$71.43
Port Clements	\$109.52
Kumdis River Lodge	\$133.33
Juskatla	\$190.48 plus off-road surcharge
New Town, Masset, Old Massett, Masset Airport	\$166.67
Tow Hill Road past BC Hydro to bridge	\$190.48
Tow Hill Road past bridge, Tow Hill, Agate Beach, North Beach	\$214.29 + Naikoon Park fees
Sandspit Airport	\$47.62 per hour or portion thereof, plus ferry costs, time starting and ending at business address of Eagle Transit Ltd., subject to minimum \$100 not including ferry costs
Moresby Camp	\$47.62 per hour or portion thereof plus ferry costs and off-road surcharge, time starting and ending at business address of Eagle Transit Ltd., subject to minimum \$100 not including ferry costs or off-road surcharge

Rates reflect one-way travel with no requested stops or waiting; GST not included

EAGLE TRANSIT LTD.

TRANSPORTATION SERVICE: Taxi

Rates at August 8, 2016

Additional Charges	
½ hour rate or portion thereof	\$33.33
Hourly rate or portion thereof	\$47.62
Cancellation charge on a booked if cancelled less than 2 hours prior to commencement of trip except for trips within Queen Charlotte or Skidegate	Regular fare
Cancellation charge on a booked trip if cancelled less than 24 hours prior to commencement of trip except for trips within Village of Queen Charlotte or Skidegate	\$47.62 or the amount of any expenses incurred by Eagle transit as a condition of charter (including wages for a driver if trip assigned), whichever is greater
Dismissal fee	\$7.62
Minimum fare for multiple passenger group(s)	\$7.62 per group
Minimum fare for trips that are charged, billed to third-party or paid by credit card	\$14.29
Cleaning charge	\$23.80
Requested stop, no waiting	\$.95
Requested stop and wait up to maximum 15 minutes or portion thereof	\$1.90 per 5-minute increments or portion thereof
Return trip to point of origin or a change in direction (east/west, north/south)	2 x applicable fare
Discount for fares billed to a valid Eagle Transit charge account for travel within and between Village of Queen Charlotte and Skidegate	A discount of \$3.81 will apply to any round or return trip within same day for the same passenger(s), subject to minimum charge of \$14.40. Single trips are subject to regular fares and minimums
Travel on logging or forestry roads such as but not limited to Rennell Sound, Juskatla, Grey Bay, Copper Bay, Kagan Bay, Moresby Camp	Add \$47.62 to regular fare
Travel to or within Naikoon Park	\$1.90 per passenger

GST not included



BOARD HIGHLIGHTS

August 12, 2016 Board Meeting

Board Business:

1. The Board received correspondence from the Honourable Peter Fassbender, Minister of Community, Sport and Cultural Development advising the Skeena-Queen Charlotte Regional District (SQCRD) Board that it had received the requisite information required for him to make a recommendation to the Lieutenant Governor in Council that it change the name of the SQCRD to the "North Coast Regional District".
2. The Board, following receipt of correspondence from the Prince Rupert Unemployed Action Centre Society (PRUACS), provided a letter of reference to the PRUACS for future funding applications to support the hiring of a second advocate for the Prince Rupert Unemployed Action Centre.
3. The Board adopted the following Board policies:
 - Asset Management Policy;
 - Business Case Policy;
 - Conflict of Interest Policy;
 - Purchasing Policy; and
 - Permissive Tax Exemption Policy.
4. In keeping consistent with the SQCRD Electoral Areas D and E Emergency Program Implementation Bylaw No. 460, 2004, and those requirements of the *Emergency Program Act*, the Board resolved to adopt the "All Islands Emergency Planning Committee Terms of Reference" to ensure the development and implementation of an emergency management program and an emergency plan for those areas.
5. The Board resolved to send correspondence to various provincial Ministers with regard to the proposed Aurora LNG Project footprint incursion into the Dodge Cove Official Community Plan boundary.

For complete details of the August 12, 2016 Board meetings, the Agenda and Minutes are posted under "Quick Links" at www.sqcrd.bc.ca.

Legislative Office
Room 201 - Parliament Buildings
Victoria, BC Canada V8V 1X4

Constituency Office
818 3rd Ave W
Prince Rupert, BC Canada V8J 1M6
P: (250) 624-7734
F: (250) 624-7737
E: jennifer.rice.mla@leg.bc.ca



August 9, 2016

Mayor & Council
C/o Kim Mushynsky, CAO
Village of Port Clements
PO Box 198
Port Clements BC V0T 1R0

Dear Mayor and Council,

I just wanted to acknowledge how impressed I was with the community spirit displayed by Port Clements at the recent Canada Day celebrations. Community volunteers really pulled together an amazing weekend of events that displayed the community's history and good-natured personalities. The detailed floats and creative costumes in the parade had me laughing out loud. Events were well-organized and engaging for both kids and adults. The food was delicious and activities were so much fun!

Having had the opportunity to participate hands-on with mud bogging is up there as one of the most interesting activities I have encountered since becoming your provincial representative. I will never forget the experience. Thank you for that.

Sincerely,

A handwritten signature in blue ink that reads "Jennifer Rice".

Jennifer Rice, MLA North Coast
NDP Opposition Spokesperson for Northern and Rural Health
NDP Opposition Deputy Spokesperson for Children and Family Development

Ruby Decock

From: Statistics Canada / Statistique Canada <statcan.censuscomm-commmdurecens.statcan@canada.ca>
Sent: August-31-16 10:38 AM
To: deputy@portclements.ca
Subject: 2016 Census of Population Program / Programme du Recensement de la population de 2016



(La version en français suit.)

Dear Mayor Gould,

I would like to thank your municipality for the strong support provided to the 2016 Census.

With outstanding engagement from Canadians from coast to coast and unwavering support from municipal governments and community organizations, Statistics Canada achieved its best census ever.

Canadians' response rate of 97.8 per cent to the 2016 long form is the best ever recorded. With the active participation by 9 in 10 Canadian households who completed their short and long-form questionnaire without assistance from Statistics Canada, and the world-record Internet response rate of 68.3 per cent, 2016 is undeniably the most efficient among traditional censuses conducted in the world.

These impressive results coupled with an overall collection response rate of 98.4 per cent will yield high-quality information for virtually all communities across Canada.

Statistics Canada now shifts its focus to dissemination with a first data release on February 8, 2017, launching an accelerated release schedule that will provide Canadians with all census data within 18 months of collection.

Please pass along our thanks to your staff. Thank you again for your support.

Wayne R. Smith

Chief Statistician of Canada
Statistics Canada / Government of Canada
wayne.smith@canada.ca / Tel: 613-951-9757

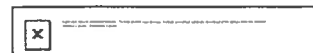

Monsieur le Maire,

VILLAGE OF PORT CLEMENTS

BYLAW NO. 434, 2016

**A BYLAW TO AMEND THE DANGEROUS DOG
BYLAW #390, 2012**

- A. WHEREAS** the Village of Port Clements Council has deemed it prudent and necessary to formally regulate dogs within the Municipal boundaries
- B. NOW THEREFORE**, the Council of the Village of Port Clements in open meeting assembled, ENACTS AS FOLLOWS:

C. Title

This Bylaw may be known and cited as the "Village of Port Clements Amended Dog Bylaw, No. 434, 2016".

D. Amendment

Under Section 2 – Regulations of Bylaw 390, 2012 the Village is adding:

e) Dog owners are required to license their dogs in the Village of Port Clements. There is a one-time fee for licensing of \$15.00 which will include a tag and number being assigned to the dog. After initial licensing, owners can purchase a replacement tag for \$5.00 if the original one is lost.

E. Effective Date

This bylaw shall come in to effect January 1, 2017.

READ A 1ST TIME THIS 18th DAY OF July, 2016
READ A 2ND TIME THIS 2nd DAY OF August, 2016
READ A 3RD TIME THIS 15th DAY OF August, 2016
RECONSIDERED AND ADOPTED THIS DAY OF , 2016

Ian Gould – Mayor

Kim Mushynsky - CAO

VILLAGE OF PORT CLEMENTS

BYLAW NO. 435, 2016

**A BYLAW TO IMPLEMENT A BYLAW ENFORCEMENT
TICKET INFORMATION BYLAW**

A. WHEREAS by Section 260 and Division 3 of Part 8 of the *Community Charter* the Council is authorized by bylaw to:

- (a) designate a bylaw for the purpose of this section, other than a bylaw in relation to a matter prescribed by regulation;
- (b) designate as a Bylaw Enforcement Officer, a person who comes within a class of persons prescribed by regulation; and
- (c) authorize the use of any word or expression on a ticket to designate an offence against a bylaw.

B. NOW THEREFORE, the Council of the Village of Port Clements in open meeting assembled, ENACTS AS FOLLOWS:

1. Title

This Bylaw may be known and cited as the "Village of Port Clements Bylaw Enforcement Ticket Information Bylaw, No. 435, 2016".

2. Designation of Bylaws to be Enforced by Ticket

The bylaws listed in Column I of Schedule 1 to this bylaw may be enforced by means of a ticket in the form prescribed for the purpose of Section 264 of the *Community Charter*.

3. Designation of Bylaw Enforcement Officers

The persons appointed to the job positions or titles listed in Column II of Schedule 1 to this bylaw are designated as Bylaw Enforcement Officers pursuant to Section 264 of the *Community Charter* for the purpose of enforcing the bylaws listed in Column I of Schedule 1 opposite the respective job positions.

4. Designation of Offences

The words or expressions set forth in Column I of Schedules 2 to this bylaw designate the offence committed under the bylaw section number appearing in

Column II opposite the respective words or expressions.

5. Designation of Fines

The amounts appearing in Column III of Schedule 2 to this bylaw are the fines set pursuant to section 265 of the *Community Charter* for the corresponding offences designated in Column I.

6. Schedules

For the purposes of this bylaw, Schedules 1 & 2 are attached to and form part of this bylaw.

7. Effective Date

This bylaw shall take effect January 1, 2017.

READ A 1ST TIME THIS 18th DAY OF July, 2016
READ A 2ND TIME THIS 2nd DAY OF August, 2016
READ A 3RD TIME THIS 15th DAY OF August, 2016
RECONSIDERED AND ADOPTED THIS DAY OF , 2016

Ian Gould – Mayor

Kim Mushynsky - CAO



SCHEDULE 1

Column I

Designated Bylaws

1. Village of Port Clements Dog
Bylaw No. 390, 2012
And Amendment Bylaw
No 434, 2016

Column II

Designated Bylaw Enforcement Officers

Animal Control Officer
Bylaw Enforcement Officers
CAO
Royal Canadian Mounted Police

SCHEDULE 2

COLUMN I	COLUMN II	COLUMN III
Village of Port Clements Dog Control Bylaw No.390, 2012 & Amendment No. 434, 2016	Section of Bylaw	Amount of Fine
1. No licence	Section 2(e)	\$ 25.00
2. Dog at large (1 st offence in a year)	Section 2(a)	\$ 50.00
3. Dog at large (2 nd offence in a year)	Section 2(a)	\$ 75.00
4. Dog at large (more than 2 offences)	Section 2(a)	\$ 100.00 each time

VILLAGE OF PORT CLEMENTS

Cheque Listing For Council

2016-Aug-31
11:35:20AM

Cheque #	Cheque Date	Vendor Name	Invoice #	Invoice Description	Invoice Amount	Cheque Amount
160406	2016-08-18	BC HYDRO	July222016	PAYMENT HYDRO	2,580.47	2,580.47
160407	2016-08-18	Bird, Brent	707101	PAYMENT BIOMASS/SANISTATION/WTP	360.00	360.00
160408	2016-08-18	Black Press Group Ltd.	32940568	PAYMENT CUSTODIAL CONTRACT AD	145.07	145.07
160409	2016-08-18	Board of School Trustees	1617-002	PAYMENT GRAYDON SECURITY	31.35	31.35
160410	2016-08-18	CIBC VISA	July212016	PAYMENT MCAFEE INTEL SECURITY	107.34	107.34
160411	2016-08-18	MARRS, SHANE	Aug52016	PAYMENT FIREWOOD FOR SUNSET PARK	150.00	150.00
160412	2016-08-18	MasterCard, CUETS FINANCIAL	July312016	PAYMENT CANADA POST	480.06	480.06
160413	2016-08-18	MUNICIPAL INFORMATION SYSTEMS INC	20160871	PAYMENT IT SUPPORT	305.98	305.98
160414	2016-08-18	Northern Savings Insurance Services Ltd.	99177	PAYMENT COMMERCIAL INSURANCE	6,840.00	6,840.00
160415	2016-08-18	SKEENA QUEEN CHARLOTTE REG'L DIST.	August32016	PAYMENT GARBAGE BILLINGS - RES & CO	13,918.50	13,918.50
160416	2016-08-18	Stewart, McDannold, Stuart	73629	PAYMENT VYSE ESTATE CEMETARY ACQL	171.36	171.36
160417	2016-08-18	TELUS COMMUNICATIONS INC.	July282016	PAYMENT TELEPHONE	1,291.56	1,291.56
160418	2016-08-18	Wright, Keirnan	August162016	PAYMENT CAMPGROUND ATTENDANT	280.00	280.00
160419	2016-08-18	XEROX CANADA LTD.	F49503441	PAYMENT COPIES	183.05	183.05
160420	2016-08-19	Edley Imagineering Inc.	2143	PAYMENT SPRINGBOARD SIGN FOR SUNS	694.40	694.40
160421	2016-08-19	Saunders, Ruby	August192106	PAYMENT MILEAGE FOR USE OF PERSON	63.08	63.08
160422	2016-08-22	Fleming, Amber Marie D	August22,2016	PAYMENT REFUND CREDIT ON TAX FOLIO	776.96	776.96
160423	2016-08-30	AARON MARK SERVICES LTD	2069646A	PAYMENT 2 X 6 LUMBER & DELIVERY FOR	205.53	205.53
160424	2016-08-30	GHW Appraisals, Northwest Ltd.	16-165	PAYMENT APPRAISAL REPORT FOR DL 99	630.00	630.00
160425	2016-08-30	RECEIVER GENERAL - CRA	20160705	PAYMENT REMITTANCE	3,549.06	3,549.06
160426	2016-08-30	ROCKY MOUNTAIN Phoenix	IN98420	PAYMENT FIRELINE TAPE 3" PCVFD	69.51	69.51
160427	2016-08-30	WEIGUM, SHIRLEY	031803	PAYMENT JANITOR SERVICES FOR AUGUS	1,175.00	1,175.00
160428	2016-08-30	Wright, Keirnan	20160830	PAYMENT SUNSET PARK CAMPGROUND A	280.00	280.00

VILLAGE OF PORT CLEMENTS

Cheque Listing For Council

2016-Aug-31
11:35:20AM

Cheque #	Date	Vendor Name	Invoice #	Invoice Description	Invoice Amount	Cheque Amount
----------	------	-------------	-----------	---------------------	----------------	---------------

Total 34,288.28

*** End of Report ***

F-1



The Village of
PORT CLEMENTS
"Gateway to the Wilderness"

36 Cedar Avenue West
PO Box 198
Port Clements, BC
V0T1R0
OFFICE :250-557-4295
Public Works :250-557-4326
FAX :250-557-4568
Email : office@portclements.ca
Web : www.portclements.ca

REPORT TO COUNCIL

Author: Kim Mushynsky
Date: August 31, 2016
Re: Trail Project Options

Background: Anecdotally the trail extension path, as discussed at the Committee of the Whole meeting on August 22, 2016, has been around since the late 1990's. However, specifically, I found reference to it as a part of a more encompassing plan from 2008 when a Council Committee held public meetings and sent out surveys to residents.

At the request of Council, a Committee of the Whole meeting was held August 22, 2016 to discuss the trail project. There were approximately 16 members of the public who attended and participated in that meeting. Direction was given to staff to come back to the September 6 Council meeting with some options based on the discussions at the Committee of the Whole meeting.

As I see there are 5 options available to Council. They are itemized and then compared below.

1. Do nothing – specifically scrap the trail project altogether
2. Proceed with the trail project as initially presented – the only change being to a portion of the Falcon Street piece that it turns at Cedar Avenue West rather than running straight down Falcon.
3. Proceed with the trail project running it up between Beachy and Reindl's property which would make the trail come out at the far end of the mud bog area of the Community Park and then proceed with the remainder of the trail as outlined in option 2.
4. Proceed with the trail on Alder Avenue but acquire the additional 33 feet of the Alder Avenue Road allowance from Mr. Beachy and proceed with the path on the southern most edge of the road allowance to allow for future development of a road if that becomes necessary, without impacting the value put into the trail, and then proceed with the remainder of the trail as outlined in option 2.

5. Proceed with the trail but extend the portion along Bayview until it reaches Cedar Avenue West and then create a sidewalk up Cedar Avenue West and then down Park Street to connect to the Community Park and then proceed with the remainder of the trail as outlined in option 2.

Option 1 – Do nothing – scrap the project.

This option would concede that there is no value in proceeding with the trail project in any format and we would advise Gwaii Trust that we are returning their grant to them and we would repurpose the provincial funds to a different project. Pros – this option is quick and easy. Cons – we suffer some reputational risk with Gwaii Trust as this is the second time we would be returning funding to them for a trail project – the possibility exists that this may mean we would not get funding in the future from them for a trail project. This option also means that residents and tourists would not have access to additional trails within our community. Finally there is potential financial risk given that the tender has already been awarded.

Option 2 – Proceed with the only change being a turn on Falcon to exit off of Cedar Avenue West. There appeared to be good consensus on changing the path on the second portion of the trail extension due to topography concerns going down Falcon. Changing this portion of the path marginally does not change the overall concept of the trail project as it would still come out across from the Museum thereby linking three of our major parks/attractions in Port Clements. Pros – this minor change does not require any additional reporting/authorizations from any of the funders and does not change the overall length of the trail so it does not impact the tender that has already been awarded. Cons – this change does not address the concerns raised about the Alder Avenue portion of the trail.

Option 3 – Proceed with the trail running up between Reindl and Beachy's property to come out at the back end of the mud bog in the Community Park. Pros – this addresses the concerns raised in regards to the Alder Avenue portion of the trail. Cons – this would require us to purchase a strip of land from Beachy or the Province as we do not have a road allowance in that area and the Reindl property has a panhandle which does not leave enough space for us to purchase property from that owner for this purpose. I have spoken with BC Assessment Authority as one of our plans seems to indicate that there is a 10 meter strip between these two properties. BCAA indicated that they have conflicting data on this area but that if there is actually a 10 meter strip between the properties it belongs to the Crown. I have a call in to the Ministry in regards to the process required to lease or purchase that strip of land from the Crown. If it is Crown land, based on the previous two Crown grant applications the Municipality has made in the past five years, we are looking at a 12-18 month delay if we need to seek Crown approval to proceed.

3

Option 4 – Proceed with the trail running up Alder Avenue but acquire the remaining 33 feet of road allowance from Mr. Beachy and have the trail run on the southern side of the road allowance. Pros – this should address the concerns raised by property owners along the Alder Avenue right of way as it would move the path approximately 23 feet further south from the survey stakes recently placed along Alder Avenue. This option would mean that instead of a path being created in what would be the middle of a road, should Alder Avenue ever be developed into a road, it would instead be created in the portion of the road that is allotted for sidewalks so we would not lose the value of works put into creating the trail by the potential future creation of a road. Cons – there would be additional costs incurred for the project as this portion of land would need to be purchased and surveyed and registered with Land Titles. However initial discussions have occurred with Mr. Beachy and as there are some existing water line issues associated with the Alder Avenue right of way, this option would also address those issues.

Option 5 – Proceed with the trail but extend the Bayview portion of the trail all the way to Cedar Avenue West and then proceed up Cedar Avenue west and then down Park Street to the Community Park. Pros – this should address the concerns raised by property owners along the Alder Avenue right of way. Another positive is that it would extend the walkable area along Bayview. Cons – I have spoken with Gwaii Trust and this alteration would require us to send written request to them for permission to amend our initial application – we do not have any guarantees that this amendment would be approved until they meet and make that decision as a group. The two key points of our initial application which were relevant in it getting approved were that they liked the fact that we were connecting park/tourist attraction areas of our community with this trail project and that it was a trail as opposed to “sidewalks”. A “sidewalk” is a path alongside a road – there is no relevance as to whether it is concrete or crushed rock or paving stones – it is the location rather than the materials of construction that identify it as a sidewalk. A trail is considered to be something that runs through a more natural environment. This alternative is also materially different from the original one and may require a re-tender of the project and therefore some potential risk due to the fact that we have already awarded the tender for this project.

Of relevance to all but option 1, we are heading into the wet season which makes trail building more challenging. Our target would be to have the project finished by yearend. This isn't an absolute date as Gwaii Trust has often granted extensions to projects, especially if substantial work has already commenced, but there is the possibility that it could negatively impact any applications to Gwaii Trust in January 2017 for the next Major Infrastructure program call if we have an unfinished project on the books.

Another consideration is that all options except 1 & 3 will require us to get a permit from the Ministry of Transportation in regards to the portion of the trail that runs along Bayview in the Highway right of way. We started the process after our meeting with Highways on August 17 but have stopped any further correspondence until I am certain if the project is proceeding and if so how far along Bayview it will encompass.



The Village of
PORT CLEMENTS
"Gateway to the Wilderness"

36 Cedar Avenue West
PO Box 198
Port Clements, BC
V0T1R0
OFFICE :250-557-4295
Public Works :250-557-4326
FAX :250-557-4568
Email : office@portclements.ca
Web : www.portclements.ca

REPORT TO COUNCIL

Author: Kim Mushynsky
Date: August 30, 2016
Re: Bylaw review

Background: Due to a desire to stimulate the economy of Port Clements, the Village of Port Clements wants to review the Zoning, Building and Sub-Division Bylaws and is interested in partnering with the Village of Queen Charlotte to hire a contractor to assist with this review. This partnership will potentially reduce the costs associated with contractor travel; however, each Council will retain the right to make independent decisions. The UBCM Gas Tax funding under the Community Works Fund can be used for integrated community sustainability plans, including community plans.

As neither community has conducted this type of review in the past it is hard to estimate the costs. In coordination with the CAO of the Village of Queen Charlotte, a Request for Proposals has been developed (attached) to solicit bids for the project. Once the bids are received, both Councils will be presented with the results and recommendations.

Recommendation:

1. That Council approves the issuance of a joint Request for Proposals with the Village of Queen Charlotte for a Bylaws/Policy review project.
2. That Council determines whether to proceed with the project using the UBCM Gas Tax funding once bids are received and reviewed.

Respectfully submitted:



Request for Proposals Bylaw and Policy Review

The Village of Queen Charlotte ("VQC") and the Village of Port Clements ("VPC") request proposals from professional, qualified, experienced companies to provide a BYLAW AND POLICY REVIEW for the following:

VQC Bylaws and Policies:

1. **Official Community Plan** – update to reflect current status, consolidate Zoning/OCP amendments, and ensure alignment with Zoning and Building bylaws.
2. **Zoning Bylaw** – update the bylaw to better reflect the properties in VQC, and ensure alignment with OCP and Building bylaws.
3. **Building Bylaw** – full review and update to ensure bylaw meets new requirements, and ensure alignment with OCP and Zoning bylaws, and consider implications of an all island Building Inspector position.
4. **Subdivision and Development of Land Bylaw** – review in general with fees, streamline process to encourage development, and ensure alignment with OCP, Zoning and Building bylaws.
5. **Fixed Fees Rents and Charges Bylaw** – review to ensure fees are reflected in appropriate bylaw.
6. **Encroachments on Municipal Land Policy** – review for removal of fees that are not reflected in a bylaw and ensure the appropriate bylaw is amended to include them.
7. Make recommendations and DRAFT any **additional bylaws** that would enhance the provision of Development Services in the VQC, including Development Approvals/Procedures/Servicing/Sign Bylaws or others.

VPC Bylaws:

8. **Zoning Bylaw** – review and consolidate and recommend repealing of old amendments.
9. **Building Bylaw** – review and update to ensure bylaw meets new requirements, and ensure alignment with OCP and Zoning bylaws, and consider implications of an all island Building Inspector position.
10. **Sub-Division Bylaw** – review in general with fees, streamline process to encourage development, and ensure alignment with OCP, Zoning and Building bylaws.

The Proponents are to provide references that attest to their past experience with bylaw and policy reviews, a price for services for each community including an estimate for travel costs for site visits with the VQC and VPC, and a sample of a bylaw that they have reviewed (before and after).

The lowest price Proposal will not necessarily be accepted. The VQC and VPC reserve the right to accept or reject any or all Proposals, accept a Proposal deemed to be in the best interests of the communities, or cancel this RFP at any time. The VQC and VPC will not be responsible for any costs incurred by Proponents in preparing a response. **While each organization retains the right to make independent decisions on this issue, we will be liaising in an attempt to provide the best solution for both of our organizations due to our shared geographic remoteness and the costs associated with travel.**

All proposals will be delivered to the Village of Queen Charlotte Office in sealed envelopes, marked with BYLAW AND POLICY REVIEW, with the Company name clearly identified on the envelope no later than 4:00 pm WEEKDAY, MONTH DAY, YEAR.

The proposals will be evaluated based on the following:

- Cost
- References demonstrating past experience with bylaw and policy reviews
- Quality of sample bylaw review

Lori Wiedeman
Chief Administrative Officer
Office: 250 559 4765 ext. 3

Fax: 250 559 4742
cao@queencharlotte.ca
Issue Date: Aug 22, 2016

PO Box 580
903A Oceanview Drive
Queen Charlotte BC V0T 1S0